

# SFP1.25G Single Fiber Transceiver

## 1 Features

1. Multi-sourced SFP package with single LC/PC receptacle;
2. Single mode single fiber bi-directional transmission
3. Up to 10~120Km with 9/125 $\mu$ m SMF;
4. AC coupled for Rx and Tx side
5. Two temperature ranges: 0°C to +70°C for commercial level, -40°C to +85°C for industrial level;
6. Operates at data rate 1.25Gbps
7. Complies with MIL-STD-883/GR-468



## 2 Applications

- 1X fiber channel
- Video monitor system
- Telecommunication system

## 3 Absolute Maximum Ratings

Parameter	Symbol	Min	Max	Unit	
Storage Temperature	T <sub>s</sub>	-40	+85	°C	
Operating Temperature	T <sub>OP</sub>	Commercial level	-20	+70	°C
		industrial level	-40	85	
Supply Voltage	V <sub>CC</sub>	-0.5	+4.5	V	
Voltage on Any Pin	V <sub>IN</sub>	0	V <sub>CC</sub>	V	
Soldering Temperature ,Time	-		260°C, 10 S	°C,S	

## 4 Recommended Operating Conditions

Parameter	Symbol	Min.	Typ	Max.	Unit	
Ambient Temperature	T <sub>AMB</sub>	Commercial level	0	-	70	°C
		industrial level	-40		85	
Power Supply Voltage	V <sub>CC</sub> -V <sub>EE</sub>	3	3.3	3.6	V	

## 5 Operating Conditions

### 5.1 Transmitter (T=25°C, V<sub>CC</sub>=3~3.6V (+3.3V))

Parameter	Symbol	Min.	Typ	Max.	Unit			
Center Wavelength	$\lambda_c$	1520	1550	1580	nm			
		1280	1310	1340				
		1470	1490	1510				
Spectral width	$\Delta\lambda$	FP@RMS	2	4	nm			
		DFB@-20dB FWHM	-	1				
Output Power	0~20km	1.25G	1310 FP	P <sub>o</sub>	-9	-	-3	dBm
			14/15 DFB		-15		-3	
	40km	1.25G	14/15 DFB		-9	-	-3	
			1310 DFB		-5		-0	

## SFP1.25G Single Fiber Transceiver

	60km	1.25G	14/15 DFB		-5		0	
	80km	1.25G	14/15 DFB		-3		2	
	100~120km	1.25G	14/150 DFB		0		3	
Extinction Ratio			ER		9		-	dB
Supply Current			I <sub>CC</sub> T		-		150	mA
Input Differential Impedance			R <sub>in</sub>			100		Ω
Data Input Swing Differential			V <sub>in</sub>		300		1200	mV
Optical Modulation Amplitude			OMA		174			μW
Transmit Disable Voltage			VD		2.0		V <sub>CC</sub>	V
Transmit Enable Voltage			VEN		0		0.8	V
Transmit Disable Assert Time							10	us
Optical Rise/Fall Time		1.25G	Tr/ Tf (20-80%)			150	260	ps
Deterministic Jitter Contribution			TX ΔDJ			20	56.5	ps
Total Jitter Contribution			TX ΔTJ			50	119	ps

### 5.2 Receiver (T=25°C, V<sub>CC</sub>=3~3.6V (+3.3V))

Parameter			Symbol	Min.	Typ	Max.	Unit	
Wavelength Range			λ <sub>c</sub>	1520	1550	1580	nm	
				1280	1310	1340		
				1470	1490	1510		
Sensitivity	20km	1.25G	P <sub>in</sub>	P <sub>MIN</sub>	-	-	-21	dBm
	40/60km	1.25G	P <sub>in</sub>		-	-	-24	
	80km	1.25G	P <sub>in</sub>		-	-	-26	
	100km	1.25G	APD				-30	
	120km	1.25G	APD				-32	
MAX. Input Power (Saturation)			P <sub>MAX</sub>	-3	-	-		
Signal Detect Assert			PA	-	-	-24		
Signal Detect De-assert			PD	-45	-	-		
Signal Detect Hysteresis			PHYS	1	-	4		
Supply Current			I <sub>CCR</sub>	-	-	150	mA	
Data Output Swing Differential			V <sub>out</sub>	400	-	1000	mV	
Signal Detect Voltage - High			VSDHC	2.0	-	V <sub>CC</sub>	V	
Signal Detect Voltage - Low			VSDL	0	-	0.8		

Notes:

switch from a high state to a low state.

1) Value of output power and sensitivity can be customized according to the demand

# SFP1.25G Single Fiber Transceiver

## 6 Pin Assignment

Pin	Descriptions	Pin	Descriptions
1	VEET	Transmitter Ground (Common with Receiver Ground)	1
2	TFAULT	Transmitter Fault.	2
3	TDIS	Transmitter Disable. Laser output disabled on high or open.	3
4	MOD_DEF(2)	Module Definition 2. Data line for Serial ID.	4
5	MOD_DEF(1)	Module Definition 1. Clock line for Serial ID.	4
6	MOD_DEF(0)	Module Definition 0. Grounded within the module.	4
7	Rate Select	No connection required	
8	LOS	Loss of Signal indication. Logic 0 indicates normal operation.	5
9	VEER	Receiver Ground (Common with Transmitter Ground)	1
10	VEER	Receiver Ground (Common with Transmitter Ground)	1
11	VEER	Receiver Ground (Common with Transmitter Ground)	1
12	RD-	Receiver Inverted DATA out. AC Coupled	
13	RD+	Receiver Non-inverted DATA out. AC Coupled	
14	VEER	Receiver Ground (Common with Transmitter Ground)	1
15	VCCR	Receiver Power Supply	
16	VCCT	Transmitter Power Supply	
17	VEET	Transmitter Ground (Common with Receiver Ground)	1
18	TD+	Transmitter Non-Inverted DATA in. AC Coupled.	
19	TD-	Transmitter Inverted DATA in. AC Coupled.	
20	VEET	Transmitter Ground (Common with Receiver Ground)	1

### Notes:

1. Circuit ground is internally isolated from chassis ground.
2. TFAULT is an open collector/drain output, which should be pulled up with a 4.7k – 10k Ohms resistor on the host board if intended for use. Pull up voltage should be between 2.0V to Vcc + 0.3V. A high output indicates a transmitter fault caused by either the TX bias current or the TX output power exceeding the preset alarm thresholds. A low output indicates normal operation. In the low state, the output is pulled to <0.8V.
3. Laser output disabled on TDIS>2.0V or open, enabled on TDIS<0.8V.
4. Should be pulled up with 4.7k - 10 kohms on host board to a voltage between 2.0V and 3.6V. MOD\_DEF(0) pulls line low to indicate module is plugged in.
5. LOS is open collector output. Should be pulled up with 4.7k – 10 kohms on host board to a voltage between 2.0V and 3.6V. Logic 0 indicates normal operation; logic 1 indicates loss of signal.

# SFP1.25G Single Fiber Transceiver

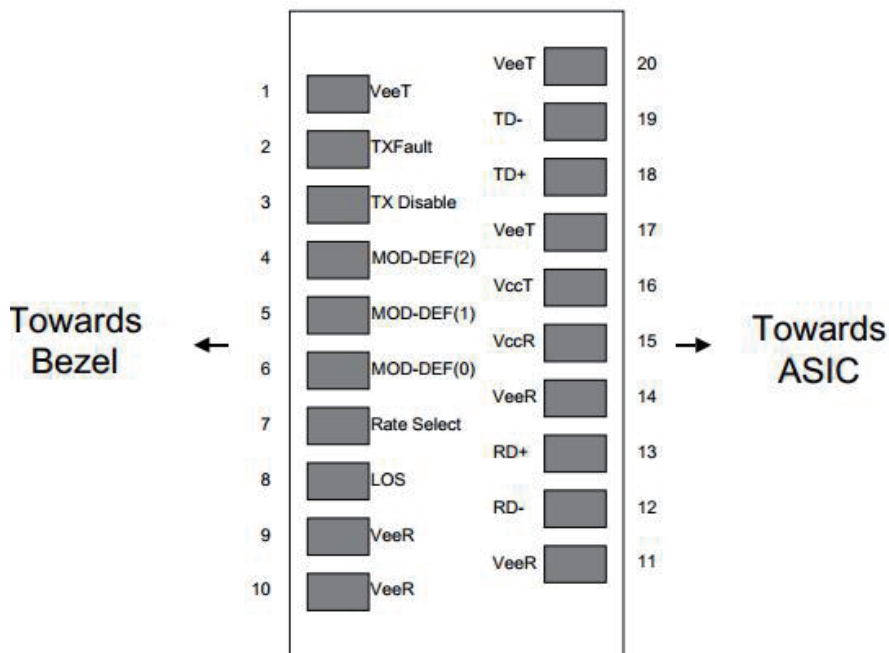

## Pinout of Connector Block on Host Board

### 7 Ordering Information

#### 7.1 Example

SFP 35 24 -F 1 1 LC-20

Sign	Mean	Description			
SFP	Module type	SFP=Single fiber SFP transceiver			
35	Center wave	35=1310tx/1550rx	53=1550tx/1310rx	45=1490tx/1550rx	54=1550tx/1490rx
24	Transmitter Rate	03=155M    03=622M	24=1.25G	48=2.5G	60=3.125G
F	Laser type	F=FP	D=DFB	C=CWDM	V=VCSEL
1	Operating T	1=0~+70°C	2=-40~+85°C		
2	DDMI	1=NO DDM	2=DDMI		
LC	Connector	SC=SC	LC=LC		
20	Distance	022=220M	055=550M	5=5KM	10=10KM
		20=20KM	40=40KM	80=80KM	100=100KM

Part No.	Wavelength	Connector	Temp.	TX Power (dBm)	RX Sens (Max.) (dBm)	Distance
SFP3524-F11LC-20	T 1310FP/R 1550	LC	-20 to 70	-9 to -3	-21	20km
SFP5324-D11LC-20	T 1550DFB/R 1310	LC	-20 to 70	-15 to -3	-21	
SFP5324-D11LC-40	T 1550DFB/R 1310	LC	-20 to 70	-9 to -3	-24	40km
SFP3524-D11LC-40	T 1310DFB/R 1550	LC	-20 to 70	-5 to 0	-24	
SFP5424-D11LC-80	T 1550DFB/R 1310	LC	-20 to 70	-3 to 2	-26	80km
SFP4524-D11LC-80	T 1490DFB/R 1550	LC	-20 to 70	-3 to 2	-26	

# SFP1.25G Single Fiber Transceiver

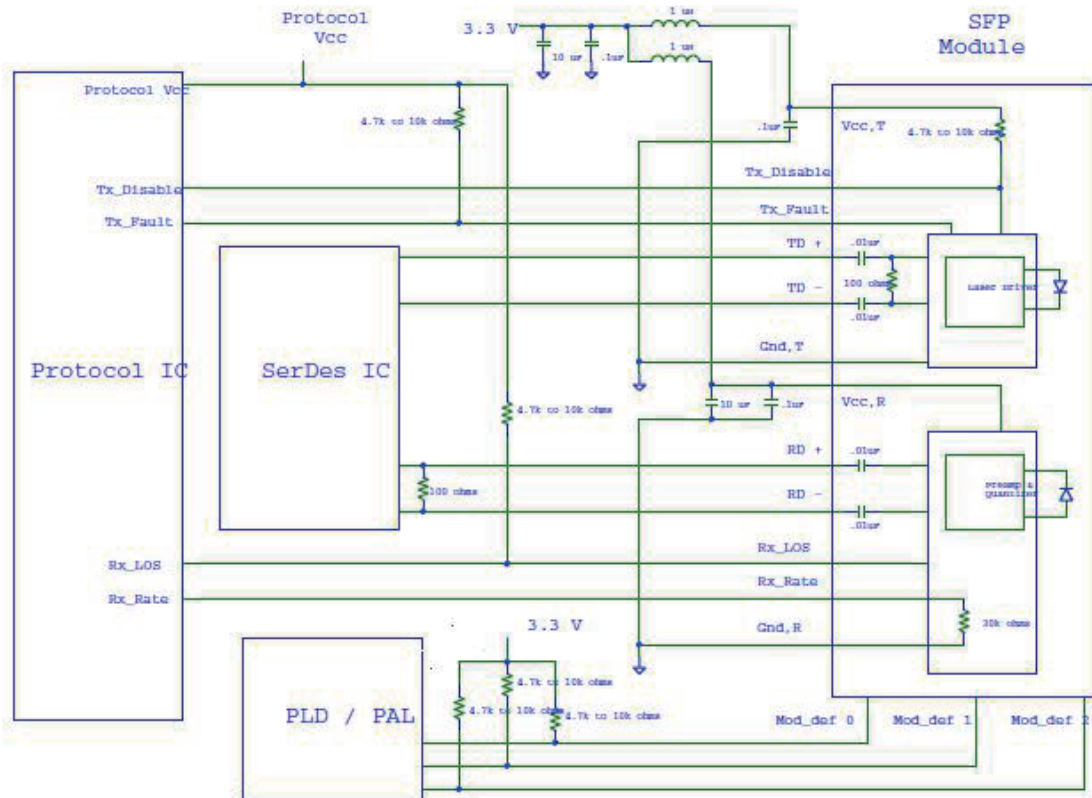

Figure 2 Example SFP Host Board Schematic

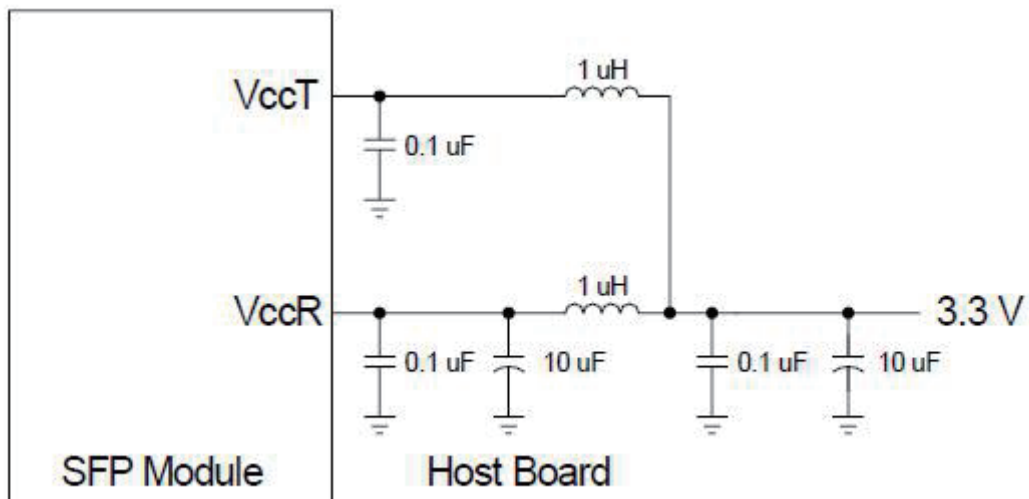

Figure 3 Recommended Host Board Supply Filtering Network

# SFP1.25G Single Fiber Transceiver

## Small Form-factor Pluggable (SFP) Transceiver MultiSource Agreement (MSA)

- Notes:
1. Datum and basic dimensions established by customer
  2. Pads and vias are chassis ground, 11 places
  3. Thru holes, plating optional

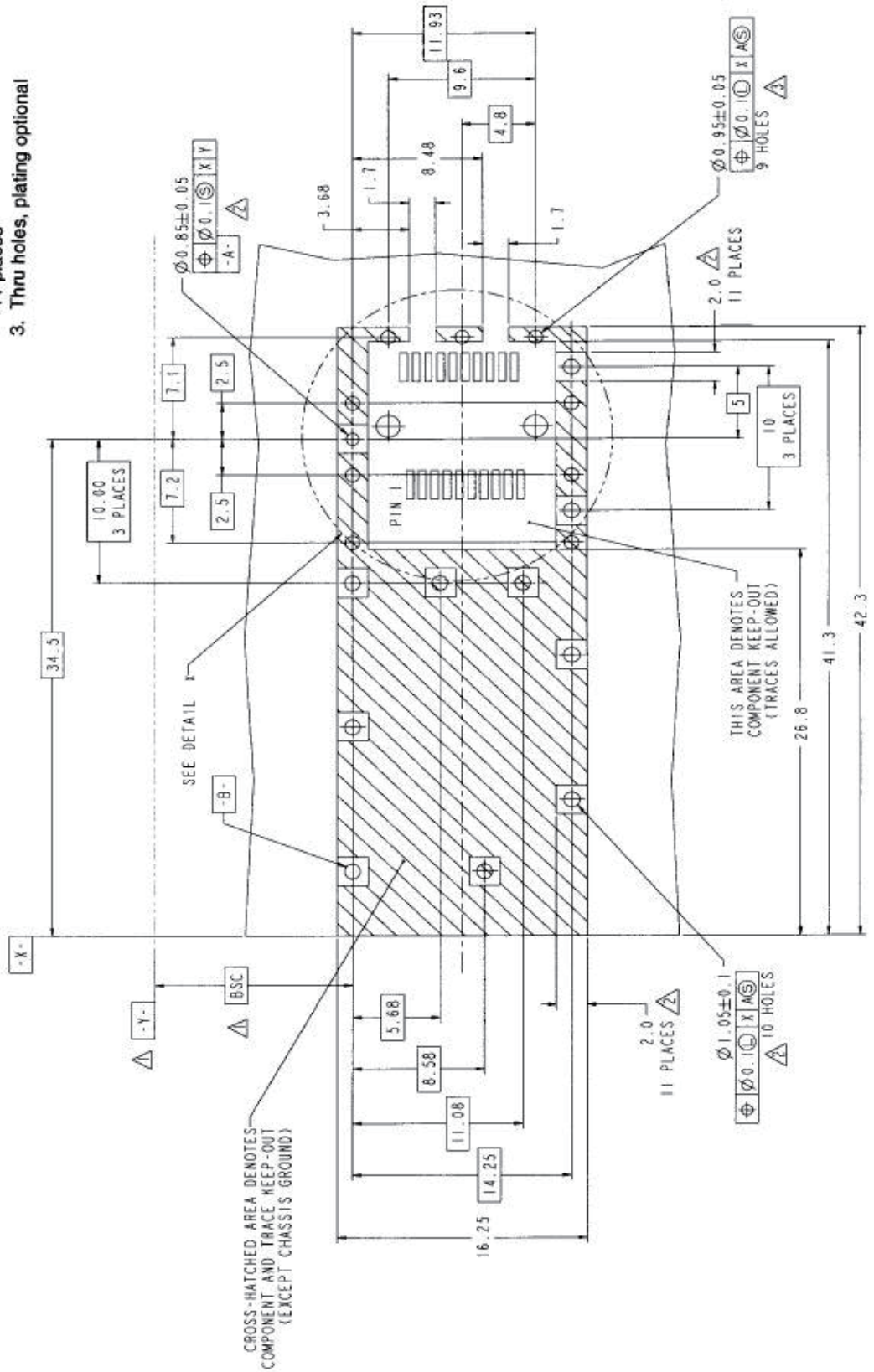

Figure 4 SFP Host Board Mechanical Layout

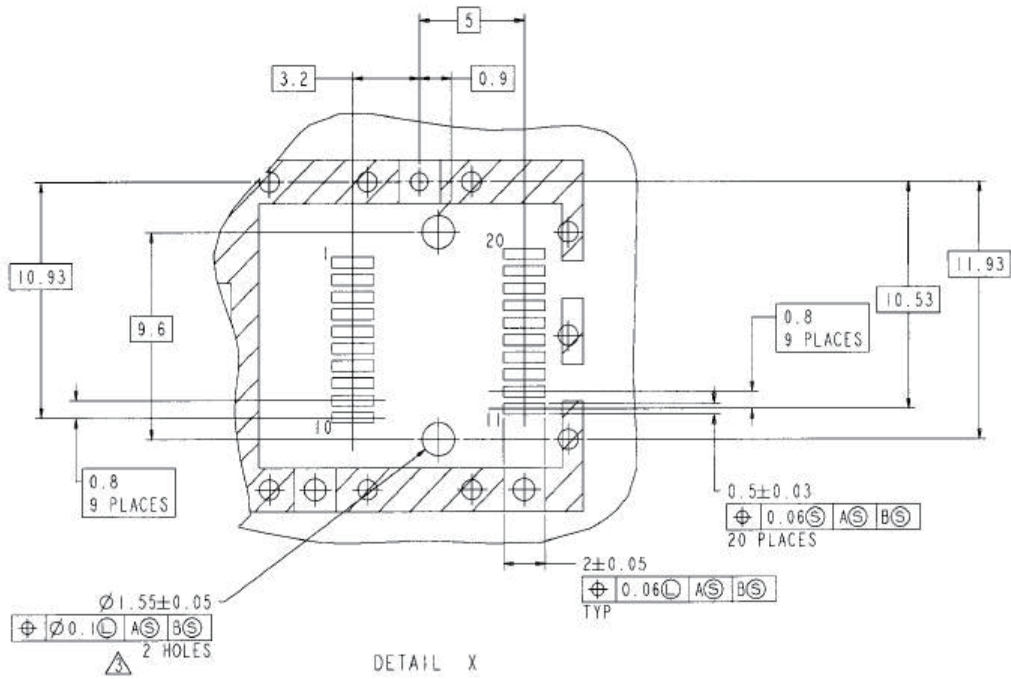
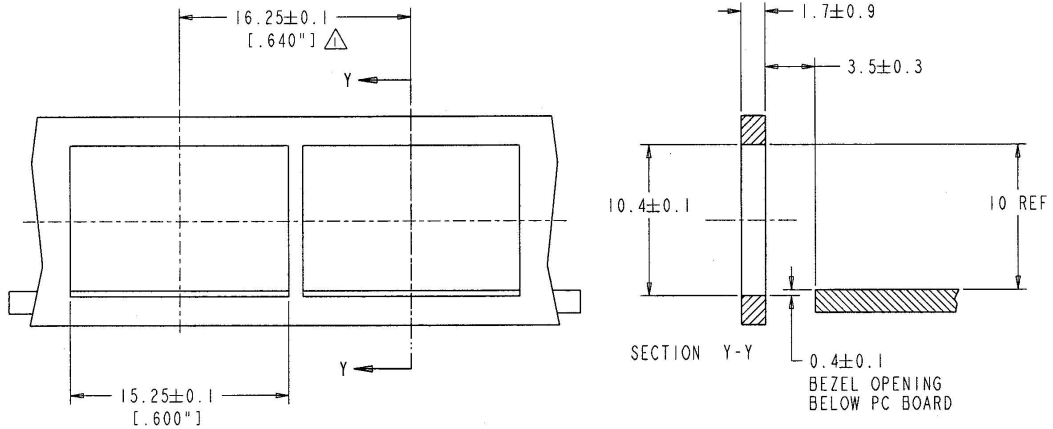

Figure 5 SFP Host Board Mechanical Layout (Cont.)



- NOTES:
- 1.  $\Delta$  MINIMUM PITCH ILLUSTRATED, ENGLISH DIMENSIONS ARE FOR REFERENCE ONLY
  - 2. NOT RECOMMENDED FOR PCI EXPANSION CARD APPLICATIONS